

M9B



Actuator for Valves with Rotating Stem

M9B is an electromechanical actuator for motorizing valves type VTRE and TRV with rotating valve stem.

M9B is available for 24 V and 230 V, 50-60 Hz. It is controlled by 3-point control.

The actuators working range is adjustable from 30 to 180 degrees of rotation.

M9B can be operated manually and indicates the valve position on front.

SPECIFICATIONS

Item number

M9B/24860-1010-000
M9B/230860-1020-000
Supply voltage	. 24 V or 230 V AC \pm 10%, 50/60 Hz
Power consumption3VA
Duty cycle 10%
Torque 15Nm
Control signal 3-point
Running time for 90° 4 min.
Auxiliary switch rating 5 A, 230 VAC
Operating temperature min-15 °C, max 55 °C
Protection standard IP54
Insulation class II
Enclosure materialReinforced plastic PA66
Colourblack/red
Weight 0,8kg

DIMENSIONS mm (in)

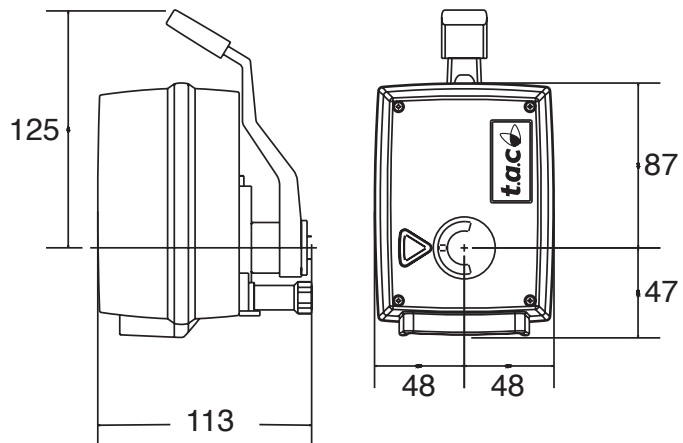

DESIGN

M9B consists of a reversible motor and a gear train in a plastic housing.

All bearings of motor and gear train are of permanent lubrication type.

The actuator can be manually operated.

The operating range of the M9B is adjustable from 30 to 180 degrees of rotation. Factory setting is 90 degrees and the actuator is in the mid position.

An auxiliary switch is operated by cam on the output shaft and the switching point can be adjusted to switch anywhere within the working range.

The position of the actuator is indicated with a pointer on the front cover.

MOUNTING KITS

The M9B is delivered with details for motorising valves type VTRE.

To use M9B on valves type TRV, additionally separately available mounting kits is necessary.

Mounting kit for Butterfly valve TRV,

Item Number: 860-0991-000

For the use of M9B on valves with 180 working range Type VTRA/STMG additionally available mounting kits is necessary.

Mounting kit for Rotating disc type valve VTRA/STMG,

Item Number: 860-0990-000

Note: For valves with working range 180 the factory setting of 90° must be changed.

WIRING

Terminals

N	System neutral
L1	24V/230V Counter-clockwise rotation
L1	24V/230V Clockwise rotation
1	Auxiliary switch, Common
2	Auxiliary switch, Normally open.
3	Auxiliary switch, Normally closed

The actuator has two knockouts for cable inlets PG11

INSTALLATION

The installation of the M9B is carried out according to instruction, shipped together with the actuator.

The actuator may be mounted beside or above the valve. Mounting below the valve should be avoided.

MAINTENANCE

Electric motor and gearbox are of permanent lubrication type and ensure a maintenance free actuator for normal operation.

DIMENSIONS mm (in)

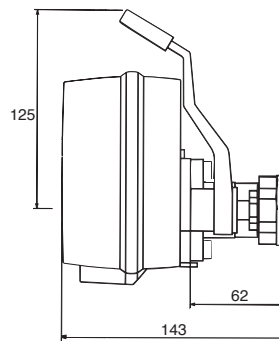

WIRING

